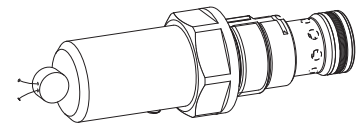

**Safety valve**
**EU - type tested**
**Pressure Equipment Directive 2014/68/EU**

- Pilot operated
- $Q_{max} = 30 \text{ l/min}$
- $p_{Nmax} = 350 \text{ bar}$

**M22x1,5**

ISO 7789

**DESCRIPTION**

Pilot operated pressure relief valve as screw-in cartridge with thread M22x1,5 for cavity according to ISO 7789. The valve is designed according to AD-2000 and EU-type tested in accordance with the Pressure Equipment Directive 2014/68/EU. As standard versions, the following preferential response pressures are available: 100, 140, 250, 330 and 350 bar. Apart from this, within the range of 50 – 350 bar response pressures can be freely selected. The cartridge body and the cover made of steel are zinc coated and therefore protected against rust and the blue locking seal made of plastic provide this quality product with a clean design.

**FUNCTION**

When reaching the set and locked seal response pressure, the main spool opens and connects the protected line with the return line to the tank. These pressure relief valves consist of a main and a pilot operation system integrated into the cartridge. The pilot operation is a direct operated pressure relief valve which acts on the main system. These safety valves are suitable for the protection of hydraulic systems with pressure accumulators, resp. pressure reservoirs. The very limited play of the hardened spool results in a limited oil leakage.

**APPLICATION**

For the protection of the maximum permissible operating pressure in hydraulic systems with pressure accumulators, resp. pressure reservoirs by the flowing out of the oil from the protected oil line P (1) to the tank line T (2). The screw-in cartridge is very suitable for mounting in control blocks and is built into the Wandfluh hydraulics NG6 and NG10 as a functional element in sandwich style plates (vertical combination) and flange-mounted valves (please refer to the separate data sheets in register 2.1). Stepped tools are available for making the receptacle bores in steel and aluminium (hire or purchase). Please refer to the data sheets in register 2.13. **Attention:** The banking-up pressure in the tank line for  $Q_{max}$  must amount to a maximum of 3 bar.

**CONTENT**

GENERAL SPECIFICATIONS .....	1
HYDRAULIC SPECIFICATIONS .....	1
SYMBOL .....	1
CHARACTERISTICS .....	2
DIMENSIONS .....	2
PARTS LIST .....	2
ACCESSORIES .....	2

**TYPE CODE**

Pressure relief valve	B	V	T	PM22	-	-	-	#	-
Pilot operated									
EU - Type tested in accordance with PED 2014/68/EU									
Screw-in cartridge M22x1,5									
Response pressure range									
50...< 160 bar									A
160...< 260 bar									B
260... 350 bar									C
Response pressure $p_A$ in bar									
Design-Index (Subject to change)									

**GENERAL SPECIFICATIONS**

Description	EU - type tested safety valve
Construction	Screw-in cartridge for cavity acc. to ISO 7789
Mounting	Screw thread M22x1,5
Ambient temperature	-20...+50 °C
Mounting position	any
Fastening	$M_D = 50 \text{ Nm}$
Weight	$m = 0,20 \text{ kg}$
Basic material	The material of the hydraulic block must be chosen in accordance to the pressure equipment directive (PED) and general safety considerations. In case of pressure above 160 bar the manufacturer advises steel with a tensile strength of at least 330 N/mm <sup>2</sup> .

**HYDRAULIC SPECIFICATIONS**

Hydraulic fluid	Mineral oils of fluid group 2, other media on request
Contamination efficiency	ISO 4406:1999, class 18/16/13 (Required filtration grade $\beta_{6...10} \geq 75$ ) refer to data sheet 1.0-50/2
Viscosity range	12 mm <sup>2</sup> /s...320 mm <sup>2</sup> /s
Fluid temperature	Standard: -20...+70 °C ATEX IIC, T6: -20 °C...+40 °C ATEX IIC, T4: -20 °C...+70 °C
Ad. volume flow	$Q_{max} = 30 \text{ l/min}$
Leakage volume flow	See curve
Preferential response pressure $p_A$	100 bar * 140 bar * 250 bar * 330 bar * 350 bar *
Individual response pressure	on request 50... 350 bar *± 3%

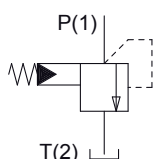
**SYMBOL**

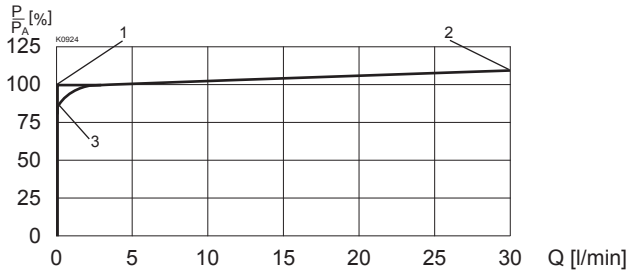
**CHARACTERISTICS** Oil viscosity  $\nu = 30 \text{ mm}^2/\text{s}$ 
 $p = f(Q)$  Pressure volume flow characteristics

- 1 Response pressure: Response pressure in accordance with type code.
- 2 Blow-off pressure: The blow-off pressure is situated a maximum of 10 % above the response pressure.
- 3 Closing pressure: The closing pressure is situated a maximum of 15 % below the response pressure.

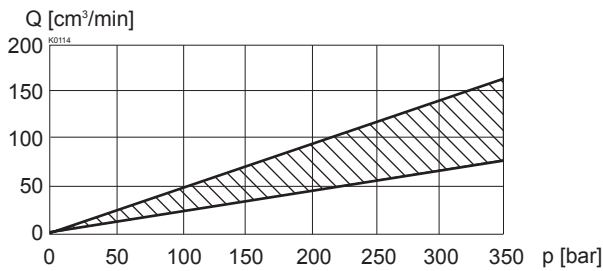
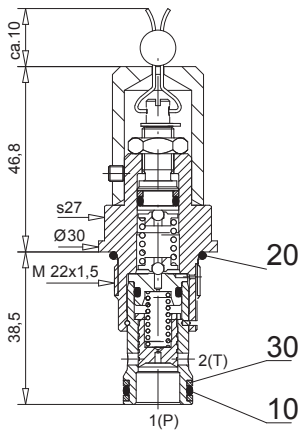
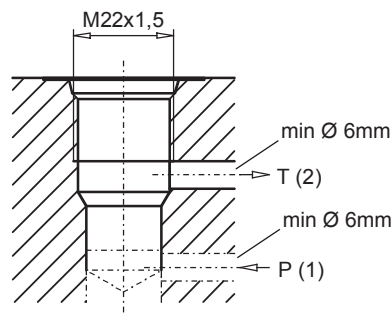
 $Q_L = f(p)$  Leakage volume flow characteristics  
 [P (1) → T (2)]

**DIMENSIONS**

 Cavity drawing to  
 ISO 7789-22-02-0-98

 Detailed cavity drawing and cavity tools  
 see data sheet 2.13-1003.

**PARTS LIST**

Position	Article	Description
10	160.2140	O-ring ID 14,00x1,78
20	160.2188	O-ring ID 18,77x1,78
30	049.3177	Back-up ring RD 14,6x17,5x1,4

**ACCESSORIES**

Cartridge built into flange- or sandwich body:

 Flange valve register 2.1  
 Sandwich valve register 2.1

 – The operating instructions incl. the EU declaration of conformity is supplied in German, English and French (download under [www.wandfluh.com](http://www.wandfluh.com))

Technical explanation see data sheet 1.0-100E