

Magnetsitzventil

- 2/2-Wege Sandwichbauart
- $Q_{\max} = 80 \text{ l/min}$
- $p_{\max} = 160 \text{ bar}$

NG10
 ISO 4401-05

TYPENBEZEICHNUNG

ZM22100b-S589-G24

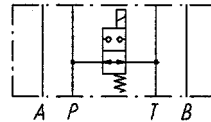
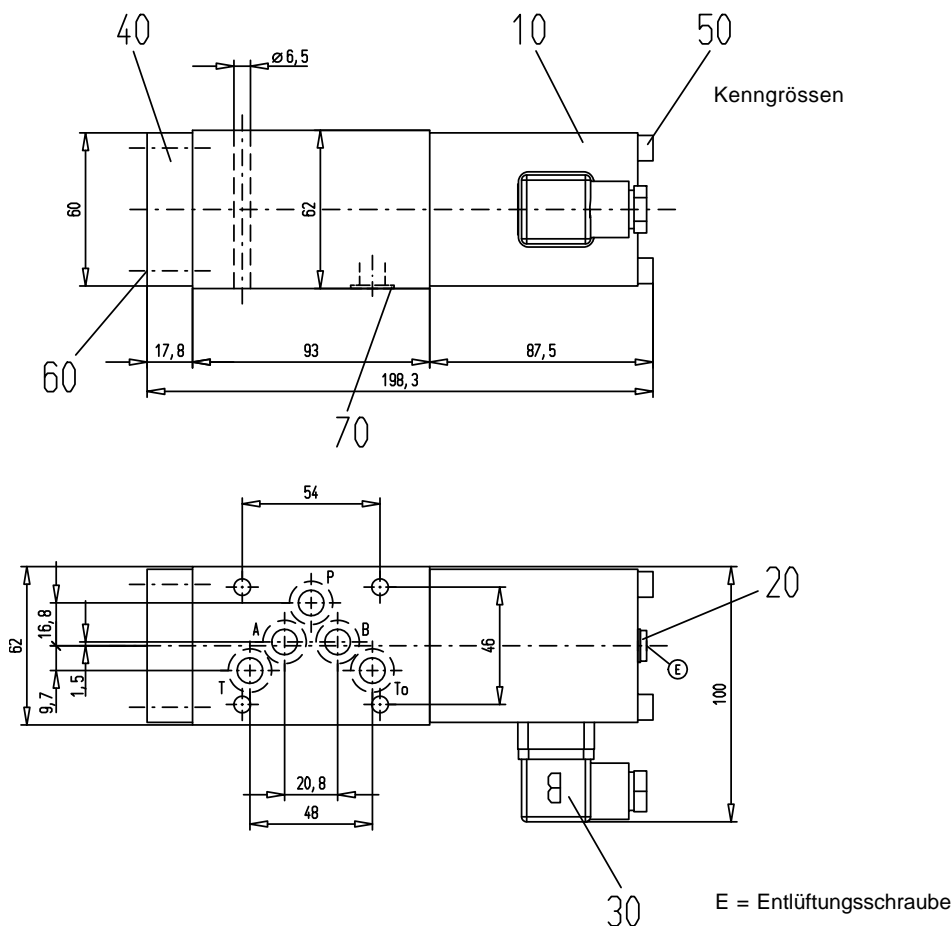
SINNBILD

ABMESSUNGEN

ERSATZTEILLISTE

Position	Artikel	Beschreibung
10	260.8453	Medium-Magnet SIN60V-G24
20	239.2033	Verschlusschraube (inkl. Dichtring) HB0
30	219.2002	Steckdose (schwarz)
40	059.2200	Deckel
50	246.3190	Zylinderschraube M6x90 DIN 912
60	249.3121	Zylinderschraube M6x20 DIN 912
70	160.2140	O-Ring ID 14,00x1,78