

Solenoid

Installation- and Operating Instructions

EU – Declaration of Conformity

Type: MKY45/18x60-*/L*-**/AUS #*

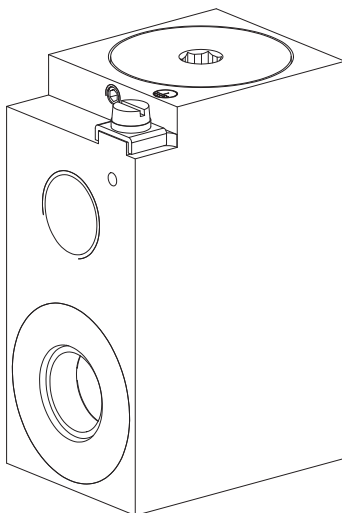

Overall view

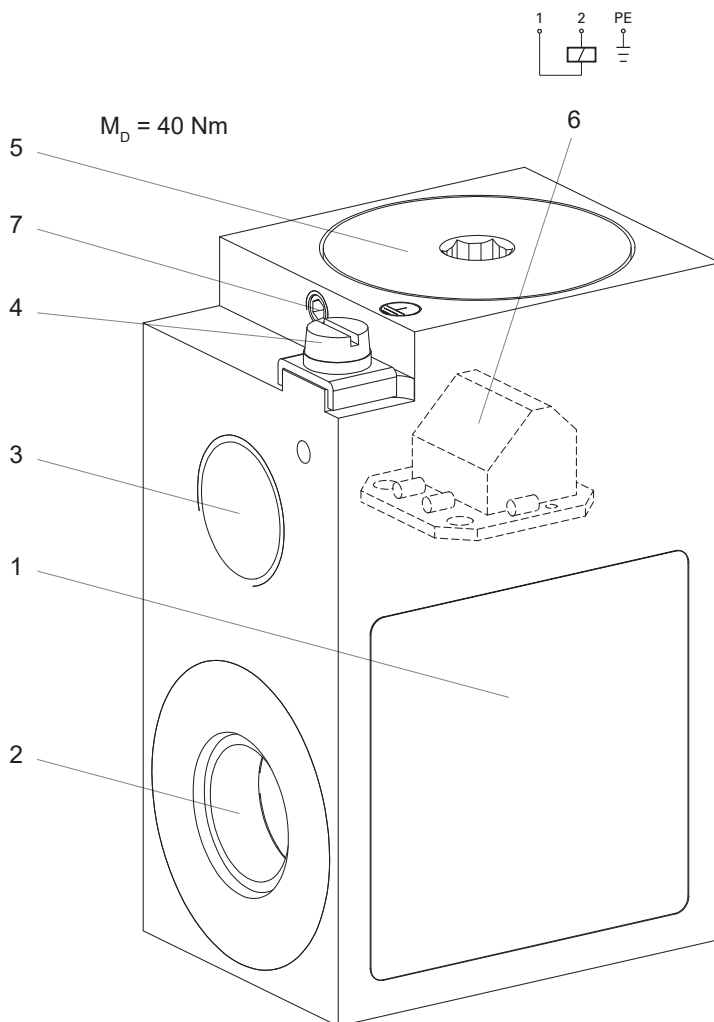

1. Name plate
2. Internal coil diameter
3. Thread for screw connection
4. Grounding connection
5. Housing cover
6. Connection terminal
7. Safety bolt

1 Safety

Use in Line with the Intended Purpose

Solenoid coils of the types **MKY45/18x60-**L*.**/AUS #*** together with armature tubes serve for the actuation of valves. The solenoid type matching valve should be selected in conjunction with the solenoid manufacturer or his representative. On the valve side, the installation conditions required for the solenoid coil have to be assured.

The solenoid coils are certified with:

- IECEx-type test certification ITA 12.0027X as devices of the group I, category M2, equipment protection level Mb as well as of the group II, category 2G and 2D. They are foreseen for utilisation in zones with explosive gas-, vapour-, mist-air mixtures of the zones 1 and 2 as well as in dust-air mixtures of the zones 21 and 22.
- EC-type test certification PTB 07 ATEX 1023 as devices of the group II, category 2G and 2D. They are foreseen for utilisation in zones with explosive gas-, vapour-, mist-air mixtures of the zones 1 and 2 as well as in dust-air mixtures of the zones 21 and 22.
- IECEx certificate of conformity IECEx PTB 10.0020 as devices of the groups IIC and IIIC. They are foreseen for utilisation in zones with explosive gas-, vapour-, mist-air mixtures in accordance with equipment protection level Gb as well as in dust-air mixtures in accordance with equipment protection level Db.
- EC-type test certification BVS 11 ATEX E 037 as devices of the group I, category M2, equipment protection level Mb.
- IECEx certificate of conformity IECEx BVS 11.0018 as devices of the group I, category M2, equipment protection level Mb.

Authorised Persons

The work described here must only be carried out by authorised persons. Authorised are persons, who have been at least «electro-technically instructed» (equivalent to EN 60 204).

About these Operating Instructions

These operating instructions are a component part of the product and have to be integrated into the corresponding operating instructions of the superordinate installations or machines.

2 General Remarks about Danger



During the installation- and connection- work there is no explosion protection. All works must only be carried out if there is no danger, in particular if no explosive atmosphere is present.



Prior to starting the connection work and the dismantling, it has to be ensured, that the operating power is switched off and is secured against unauthorised switching on.



For maintaining the explosion protection, do not fail to observe the installation remarks and adhere to the «Installation Conditions». Customer specific coating is only permitted if thickness does not exceed 200 µm.

3 Guarantee

A safe operation without any problems is only assured, if the requirements of these operating instructions are completely adhered to. Decisive for the assertion of legal rights is the German language version. In case of non-observance, Wandfluh AG assumes no liability.

Subject of technical changes and changes in the scope of delivery.

4 Type Designations

	M	K	Y	45	/	18	x	60	-	<input type="checkbox"/>	<input type="checkbox"/>	-L	<input type="checkbox"/>	<input type="checkbox"/>	/	AUS	#*	
Mobile version metal housing																		
Terminal box without cable																		
Ex d execution																		
Housing width 45 mm																		
Internal coil diameter 18 mm																		
Coil length 60 mm																		
G = direct current; R = alternating current																		
Nominal voltage in V																		
Nominal power in W																		
Thread for screw connection																		
Australian Certification																		
Design-Index (Subject to change)																		

Examples:

MKY45/18x60-G24-L15

Solenoid coil 24 V direct current, nominal power 15 W and thread for screw connection M20x1.5

MKY45/18x60-R48-L9-M187

Solenoid coil 48 V alternating current, nominal power 9 W and thread for screw connection NPT1/2"

5 Explosion Protection

Device designation in accordance with IECEx and Directive 2014/34/EU (ATEX).

The solenoid coils are identified for a power range of 6-21 Watt and a nominal voltage range of 12-230 VDC and 24-230 VAC.

Device group I, mining:

Solenoid coils of this version may be utilised in explosion hazard areas in accordance with the certifications:

12 VDC $\leq U_{Nenn} < 20$ VDC	Power	Ta min.		Ta max.
		M224	Standard	
IECEx Mining: Ex d I Mb	≤ 9 Watt	-40 °C	-25 °C	+80 °C
	≤ 12 Watt	-40 °C	-25 °C	+70 °C
	≤ 15 Watt	-40 °C	-25 °C	+60 °C
	≤ 18 Watt	-40 °C	-25 °C	+50 °C
	≤ 21 Watt	-40 °C	-25 °C	+40 °C

Table 1 Identifications for nominal voltages 12 VDC $\leq U_{Nom} < 20$ VDC

20 VDC $\leq U_{Nenn} \leq 230$ VDC 24 VAC $\leq U_{Nenn} \leq 230$ VAC	Power	Ta min.		Ta max.
		M224	Standard	
IECEx Mining: Ex d I Mb	≤ 9 Watt	-40 °C	-25 °C	+90 °C
	≤ 12 Watt	-40 °C	-25 °C	+80 °C
	≤ 15 Watt	-40 °C	-25 °C	+70 °C
	≤ 18 Watt	-40 °C	-25 °C	+60 °C
	≤ 21 Watt	-40 °C	-25 °C	+50 °C

Table 2 Identifications for nominal voltage 20 VDC $\leq U_{Nom} \leq 230$ VDC
24 VAC $\leq U_{Nom} \leq 230$ VAC

Device group I, mining:

Solenoid coils of this version may be utilised in explosion hazard areas in accordance with the certifications:

12 VDC $\leq U_{\text{Nenn}} < 20$ VDC	Power	Ta min.		Ta max.
		M224	Standard	
ATEX Mining:  I M2 Ex db I Mb	≤ 9 Watt	-40 °C	-25 °C	+80 °C
	≤ 12 Watt	-40 °C	-25 °C	+70 °C
	≤ 15 Watt	-40 °C	-25 °C	+60 °C
	≤ 18 Watt	-40 °C	-25 °C	+50 °C
	≤ 21 Watt	-40 °C	-25 °C	+40 °C

Table 1 Identifications for nominal voltages $12 \text{ VDC} \leq U_{\text{Nom}} < 20 \text{ VDC}$

20 VDC $\leq U_{\text{Nenn}} \leq 230$ VDC 24 VAC $\leq U_{\text{Nenn}} \leq 230$ VAC	Power	Ta min.		Ta max.
		M224	Standard	
ATEX Mining:  I M2 Ex db I Mb	≤ 9 Watt	-40 °C	-25 °C	+90 °C
	≤ 12 Watt	-40 °C	-25 °C	+80 °C
	≤ 15 Watt	-40 °C	-25 °C	+70 °C
	≤ 18 Watt	-40 °C	-25 °C	+60 °C
	≤ 21 Watt	-40 °C	-25 °C	+50 °C

Table 2 Identifications for nominal voltage $20 \text{ VDC} \leq U_{\text{Nom}} \leq 230 \text{ VDC}$
 $24 \text{ VAC} \leq U_{\text{Nom}} \leq 230 \text{ VAC}$

Device group II, other areas:

Solenoid coils of this version may be utilised in explosion hazard areas in accordance with the certifications:





12 VDC $\leq U_{\text{Nenn}} < 20$ VDC		Power	Ta min.		Ta max.
			M224	Standard	
IECEX:	Ex d IIC T6 Gb	≤ 8 Watt	-40 °C	-25 °C	+40 °C
IECEX:	Ex tb IIIC T80 °C Db				
ATEX:	 II 2 G Ex db IIC T6				
ATEX:	 II 2 D Ex tb IIIC T80 °C Db				
IECEX:	Ex d IIC T4 Gb				
IECEX:	Ex tD A21 IP 65 T130 °C Db	≤ 12 Watt	-40 °C	-25 °C	+70 °C
ATEX:	 II 2 G Ex db IIC T4	≤ 15 Watt	-40 °C	-25 °C	+60 °C
ATEX:	 II 2 D Ex tb IIIC T130 °C Db	≤ 18 Watt	-40 °C	-25 °C	+50 °C
		≤ 21 Watt	-40 °C	-25 °C	+40 °C

Table 1 Identifications for nominal voltages 12 VDC $\leq U_{\text{Nom}} < 20$ VDC





20 VDC $\leq U_{\text{Nenn}} \leq 230$ VDC 24 VAC $\leq U_{\text{Nenn}} \leq 230$ VAC		Power	Ta min.		Ta max.
			M224	Standard	
IECEX:	Ex d IIC T6 Gb	≤ 9 Watt	-40 °C	-25 °C	+40 °C
IECEX:	Ex tb IIIC T80 °C Db				
ATEX:	 II 2 G Ex db IIC T6				
ATEX:	 II 2 D Ex tb IIIC T80 °C Db				
IECEX:	Ex d IIC T4 Gb				
IECEX:	Ex tD A21 IP 65 T130 °C Db	≤ 12 Watt	-40 °C	-25 °C	+80 °C
ATEX:	 II 2 G Ex db IIC T4	≤ 15 Watt	-40 °C	-25 °C	+70 °C
ATEX:	 II 2 D Ex tb IIIC T130 °C Db	≤ 18 Watt	-40 °C	-25 °C	+60 °C
		≤ 21 Watt	-40 °C	-25 °C	+50 °C

Table 2 Identifications for nominal voltage 20 VDC $\leq U_{\text{Nom}} \leq 230$ VDC
24 VAC $\leq U_{\text{Nom}} \leq 230$ VAC

6 Technical Data

Nominal voltage	In accordance with name plate
Maximum admissible operating voltage	Nominal voltage +10%
Nominal frequency	In accordance with name plate $\pm 2\%$
Nominal power	In accordance with name plate
Switched-on time period	100% (continuous operation)
Relative air humidity	Max. 95% (not dew-forming)
Protection against contamination with dirt in accordance with EN 60 529	IP65
	IP67/68 only with corresponding cable gland

7 Operating Conditions

Electric power supply

- Maximum admissible residual ripple: +/-10% of the nominal voltage.
- Admissible voltage pulses:
 - Peak value ≤ 1000 V
 - Time duration $\leq 1,5$ ms
- Permissible values for voltage interruption / dropping below voltage are dependent on the valve (possibly enquire with the manufacturer).
- Each solenoid must be provided on the line side with a short-circuit protection in the form of a fuse designed to meet the solenoid current rating (max. $3 \times I_{Nom}$, recommended $2 \times I_{Nom}$ in compliance with IEC 60127-2-1) or a thermal overload trip with instantaneous short-circuit and thermal release (adjusted to match the current rating).
The current rating of the fuse in addition must not be greater than the short-circuit current of the power supply.

Nominal voltage	Nominal power					
	6 Watt	9 Watt	12 Watt	15 Watt	18 Watt	21 Watt
12 VDC	1,0 A	1,6 A	2,0 A	2,5 A	3,15 A	4,0 A
24 VDC	0,5 A	0,8 A	1,0 A	1,25 A	1,6 A	2,0 A
115 VAC	0,125 A	0,2 A	0,25 A	0,315 A	0,4 A	0,4 A
230 VAC	0,063 A	0,1 A	0,125 A	0,160 A	0,2 A	0,2 A

Table 3 Recommended current rating for fuse inserts

Enhanced requirements

Solenoid coils in this execution are foreseen for utilisation in stationary industrial hydraulics as well as in mobile hydraulics.

They have been successfully tested for temperature shock, vibration and mechanical shock.

Nonetheless the manufacturer does not guarantee the suitability and assumes no responsibility for the utilisation under extreme conditions.

8 Installation / Commissioning / Dismantling

Before starting, «Safety» and «General Remarks about Danger» have to **have been read and understood**. During the installation- and connection work there is no explosion protection. All works must only be carried out if there is no danger, in particular if no explosive atmosphere is present.

Installation

1. Slide the solenoid coil over the axial conduit of the valve. The axial conduit has to be made of steel and has to have a diameter of at least 17.8 mm. Over a length of max 15 mm it may have a diameter of at least 15.9 mm.
2. Fix with nut.
3. Tighten the nut until a to be anticipated turning or loosening of the solenoid coil by jarring is not possible anymore.

Connection work

The solenoid coil must only be connected through suitable cable – and conductor entrances, resp. piping systems, which are certified for this purpose and which have at least the protection class IP65.

They have to correspond to the requirements of the standard EN 60079-1, sections 13.1 and 13.2 and they must have a corresponding test certificate.



Cable- and line entries as well as sealing plugs of simple design must not be utilised.



In case of a connection of the solenoid coil through a pipe entry certified for this purpose, the stopping box belonging to it has to be located either directly on the solenoid housing, resp., at a distance of maximum 18" (45cm) away from it.



Devices group I, mining: conduit systems are NOT permitted.

1. Open cover (Hexagon spanner 8 mm).
2. Connect solenoid coils to supply voltage, conductor diameter 0,75-2,5 mm².
3. **In case of ambient temperatures of more than 40 °C, utilise cable or conductor with a limit temperature of min. 120 °C.**
4. Potential equalisation through internal protective conductor or external connection terminal.
5. Tighten cover firmly, tightening torque 40 Nm.
6. Secure the cover with a hexagon socket screw (Allen screw).

Commissioning

The device must only be commissioned after the completion of all the installation work, in accordance with the installation conditions.

In particular the cover has to be firmly installed and secured.

Dismantling

1. Remove connection cable (observe «General Remarks on Danger»)
2. Release fixing nut
3. Pull the solenoid coil off the axial conduit (only in a current-free condition).

	Single assembly	Stack assembly
Minimum dimensions of the valve body	38 x 38 x 54 mm	38 x 38 x 54 mm
Minimum dimensions of connection plate	30 x 50 x 50 mm	30 x 60 x 254 mm
Minimum thermal conductivity	14 W/(m·K)	14 W/(m·K)
Minimum spacing between longitudinal valve axes		84 mm

(Nominal dimensions in mm)

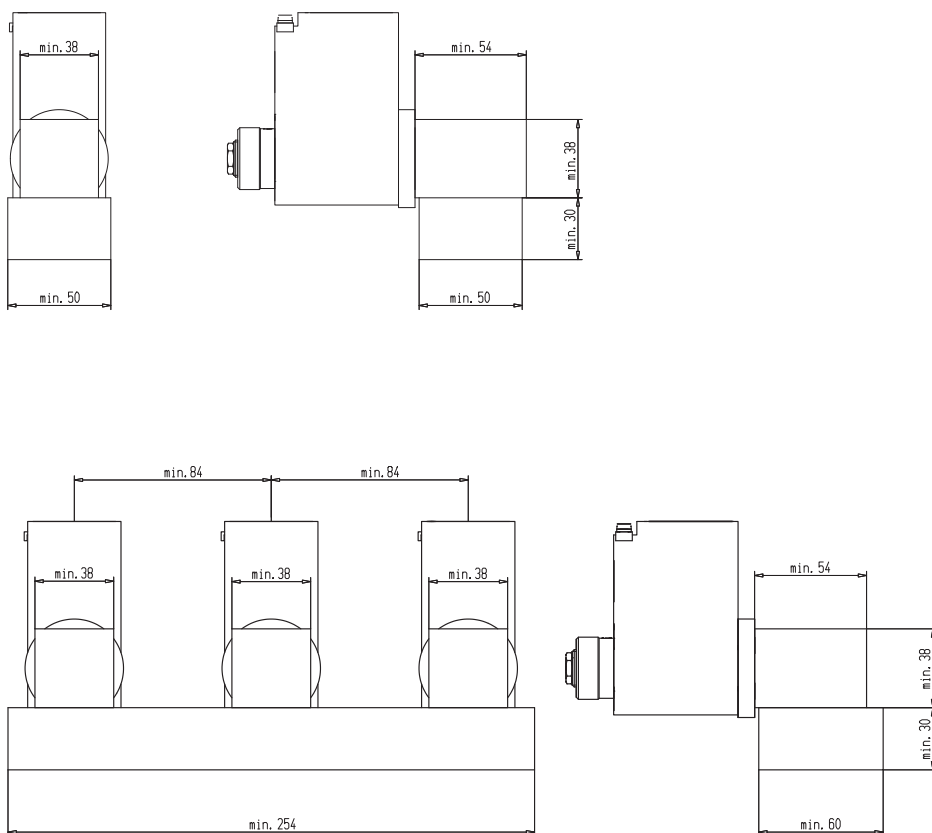

We	Wandfluh AG Helkenstrasse 13, CH-3714 Frutigen, Switzerland
Hereby declare in our sole responsibility that the product	Solenoid
Type:	MKY45/18x60-*/L*-*/AUS #*
	PTB 07 ATEX 1023 BVS 11 ATEX E 037
Under IECEX-Type Examination Certificate:	IECEX ITA 12.0027X IECEX PTB 10.0020 IECEX BVS 11.0018
Which is the subject of this declaration, is in conformity with the following standards or normative documents	

Terms of the directive	Number and date of issue of the standard
2014/34/EU ATEX Directive	EN IEC 60079-0: 2018 EN 60079-1: 2014 EN 60079-31: 2014
Production quality assessment:	SEV 16 ATEX 4130 CH/SEV/QAR16.0001
Issued by notified bodies:	TÜV Rheinland Australia Pty Ltd electrosuisse 1258

Frutigen, 4. August 2021

Place and date



Tobias Krause
Head of valve technology



Elayathamby Harrischandra
Director quality management dept.